

**CEDARAPIDS®**  
A TEREX BRAND

## Portable Plants

CRS820H  
Screen Plant

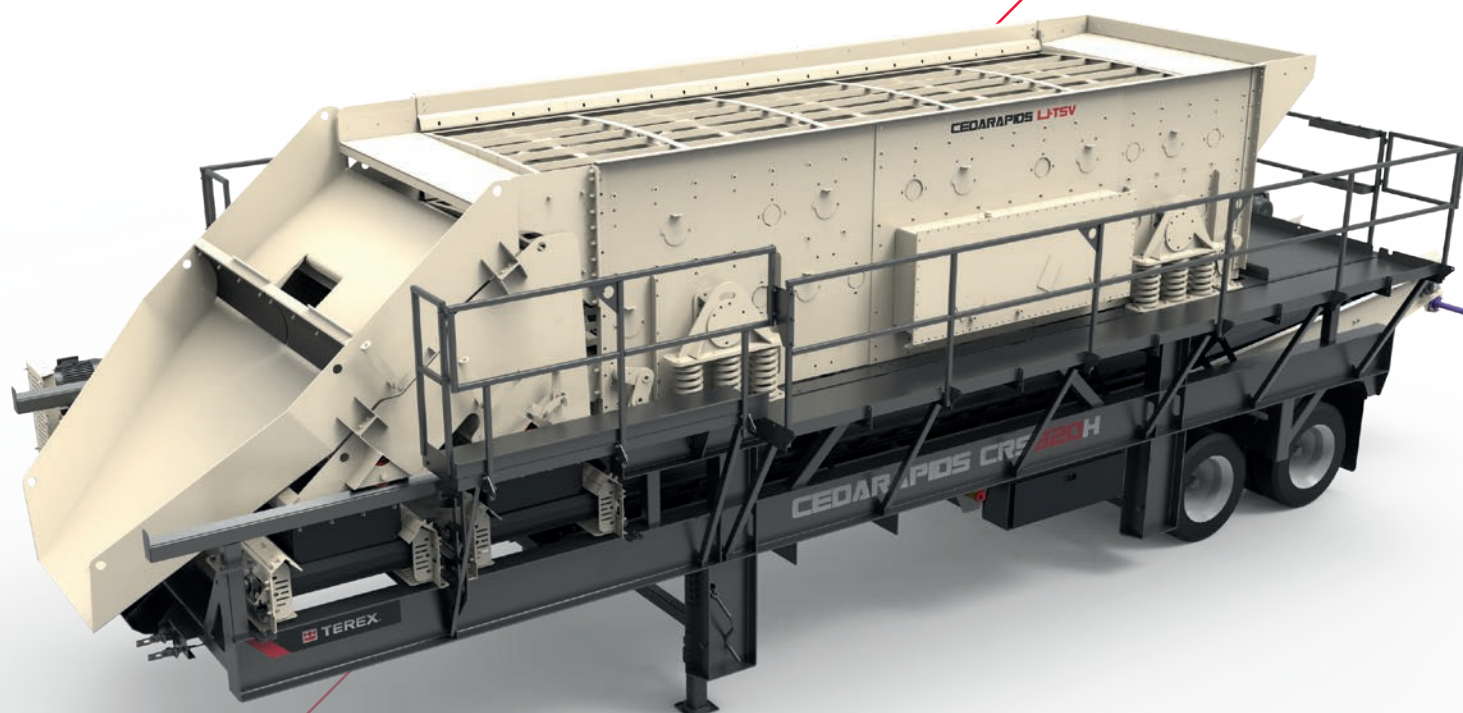

A world working better™

 **TEREX® MPS**

# Cedarapids® Portable Plants

## CRS820H Screen Plant

The Cedarapids® CRS820H screen plant features the popular 8' x 20' (2438mm x 6096mm) TSV8203 screen, along with a flex shaft screen drive and roll-away blending chutes, make this a leader in the screen plant market. The wide conveyor belts handle peak load conditions easily. The plant is designed to get the most out of the screen so there is plenty of capacity to make the crushers the bottleneck in the circuit, not the screen.

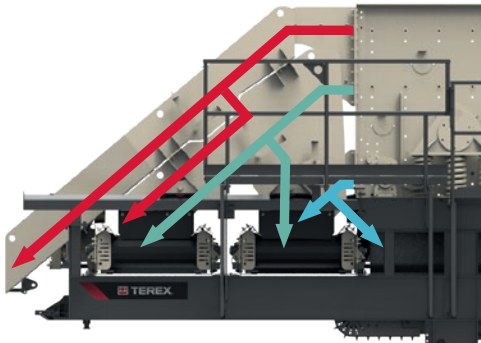

- Standard extended fines conveyor
- Optional hinged fines conveyor folds for export

Flex shaft drive folds for travel

- Roll away blending chute
- Extended Walkway option shown



Standard crank style landing jacks

Walkways fold for travel

### Standard Features

#### TSV 8203-38 heavy-duty triple-shaft oval stroke screen

- Adjustable screen stroke angle and stroke length
- 5/16" (8mm) thick side plates and beam to beam braced decks
- Patent pending low maintenance surge dampeners/ship braces
- Patented triple-shaft lubrication system
- QuickLube connections for TOPS 2.0 filter system

#### Patented low maintenance 50 hp flex shaft screen drive

- No drive belt whip or tension idler
- No drive belt pull affecting screen movement
- Drive folds for travel without shaft disassembly

#### Heavy-duty roll-away blending chutes for screen cloth access

- Heavy 3/8" (9.5 mm) AR400 steel construction
- Roll away chutes (hydraulic optional)
- Four section (25%) blending gates with individual handles combine any adjacent deck products in 25% increments

**Clamp bar stowage racks on feed end of screen walkway**

**Rugged heavy-duty conveyor systems**

- Fines Conveyor Inclined 60" (1524 mm) 10 hp (7.5kW)
- Dual 36"(915 mm) reversible 7.5 hp (5.6kW) cross conveyors
- 3 ply belts with vulcanized belt splices
- Cema C class troughing idlers and rubber disk return idlers
- Class II shaft mount gear boxes with TEFC motors
- Belt centering side roller guides
- Easy access belt take-up (end pull on cross conveyors)

**Extra-wide walkways on both sides and feed end of screen**

- Fold down sides for travel
- Non-skid surfaces can be shovel cleaned
- Walk around drive and screen incline
- Removable ladder

**Heavy Duty I-Beam main frame**

- Tandem axle 25,000 lbs (11,340kg) leaf spring suspensions
- Air brakes with spring applied emergency brakes
- Lights and splash guards
- Eight 295/75 R22.5 tires and two crank-style landing jacks

**Optional Equipment**

- Extended walkway both sides along chutes
- Hydraulic power for roll-away chutes
- Removable switchgear panel and frame with 20' (6096 mm) extra cable and cable wraps
- Two crank style rear levelling jacks
- Four hydraulic levelling or pinned run-on jacks
- Patent pending deck deflectors boosting screen effective area
- Oversize 315/80 R22.5 tires
- 2" to 3.5" (51mm to 89 mm) convertible king pin
- Magnetic screen deck liners for cross beams and diagonal braces
- TOPS 2.0 portable oil filter system
- Hinged fines conveyor for export

Specifications	Dimensions		Horsepower	
TSV8203 Screen	8' x 20'	2438 x 6096 mm	50 hp	37 kW
Underscreen conveyor	60"	1524 mm	10 hp	7.5 kW
Cross conveyors	36"	914 mm	7.5 hp	5.6 kW

Estimated Weights	Kingpin	Axles	Total
Plant*	29,770 lb (13,500 kg)	38,500 lb (17460 kg)	68,270 lb (30,960 kg)

\*Weights include optional run-on jacks, electrical and extended walkways

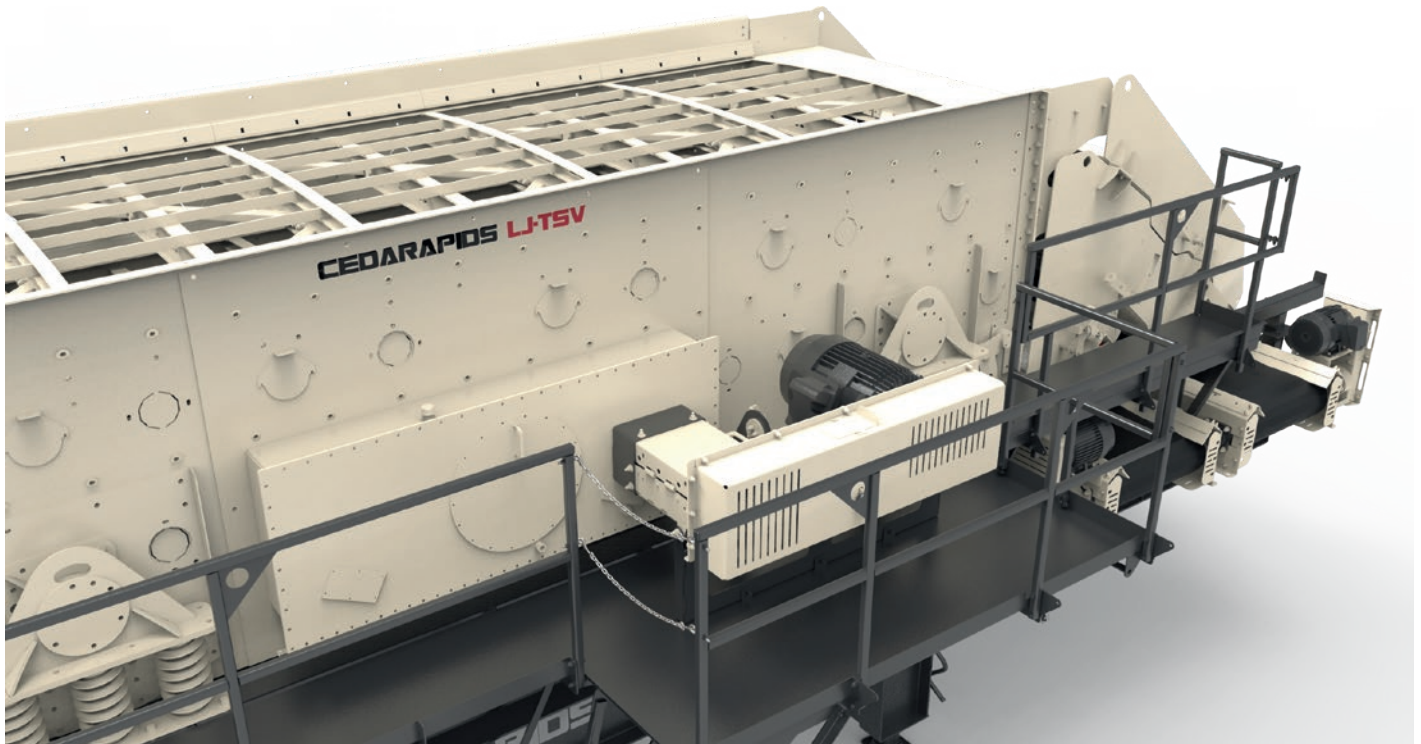

Operation Dimensions

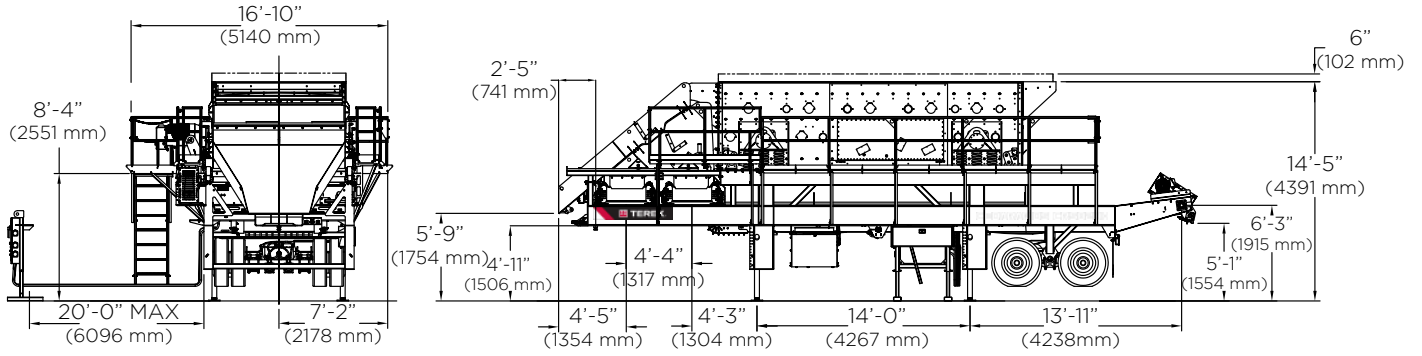

\*Ground plane based on 24" inch run-on jacks

Transport Dimensions

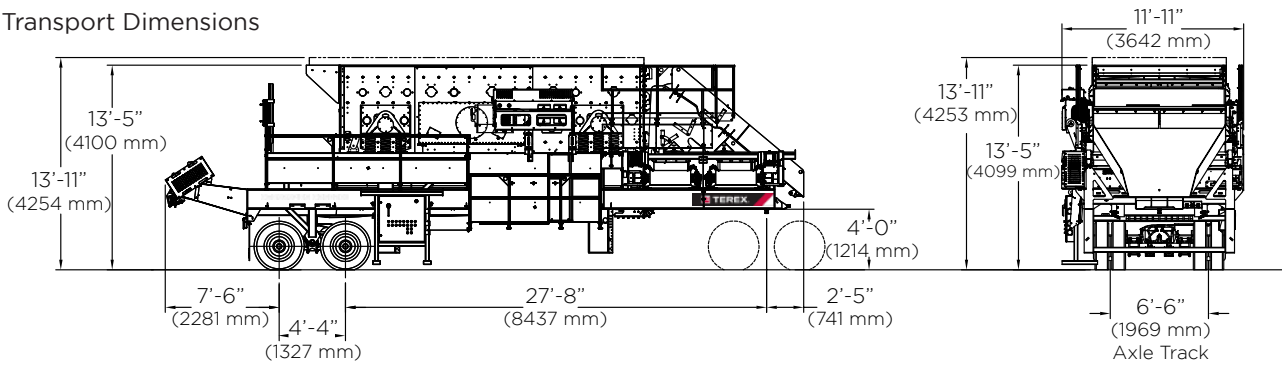

[www.terexmps.com](http://www.terexmps.com)  
[mpsmarketing@terex.com](mailto:mpsmarketing@terex.com)

Product specifications and prices are subject to change without notice or obligation. The photographs and/or drawings in this document are for illustrative purposes only. Refer to the appropriate Operator's Manual for instructions on the proper use of this equipment.

Failure to follow the appropriate Operator's Manual when using our equipment or failure to act responsibly may result in serious injury or death.

The only warranty applicable to our equipment is the standard written warranty applicable to the particular product and sale, and Terex makes no other warranty, express or implied. Terex, the Terex Crown design, Cedarapids, Canica, Simplicity, Jaques, El-Jay and Rollercone are trademarks of Terex Corporation or its subsidiaries. All rights are reserved. © July 2021

